

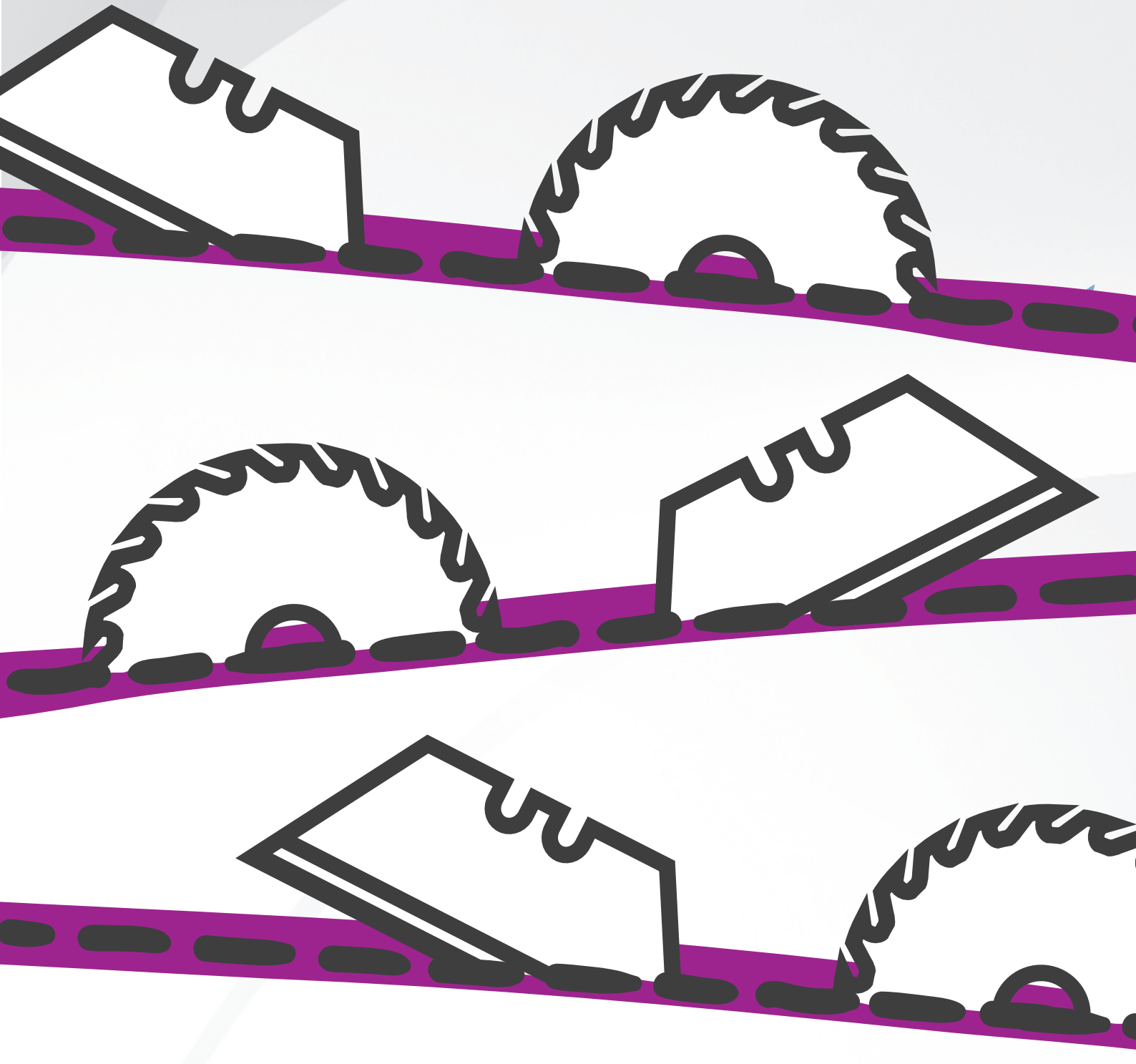

CATALOGUE

CUTTING SOLUTIONS

The widest range of cutting machinery to cover all cutting needs at the Sign market



INDEX

Vertical Cutters

Verdi Basic Vertical Saw.....	4
Verdi Twin Vertical Saw and Cutter 2 in 1	6
Wincut Pneumatic Vertical Cutter.....	8
Inblade Pneumatic / Manual Vertical Cutter	10
Inblade Pro Pneumatic Vertical Cutter	12

Cutter Bars

Inbest Basic Cutter Bar.....	14
Inbest Twin Cutter Bar	16
Inbest Pro Cutter Bar	18

Compressors.....	20
------------------	----

Dust Collectors	22
-----------------------	----



ENTER OUR WEBSITE, www.ingletmachinery.com

Where you can find all our products, news, offers and promotions with photographs and detailed descriptions... Navigate in a comfortable and easy way through the different sections or simply type in the search engine the product you want to find.



BUY IN OUR ONLINE SHOP

Register for more agility in the management of your orders.
Register on our website and get exclusive promotions!



CONSTANT INNOVATION

We present this selection of products with interesting novelties. Here you will find cutting-edge solutions to make your work easier.



PROFESSIONALS AT YOUR SERVICE

The customer is our raison d'être. At inglet you will find personalised attention to advise you and provide you with the solutions that best suit your needs.
Tel. 973 312 312 312, Fax 973 310 755, E-mail: comercial@inglet.com



KEEP YOUR MACHINERY UP TO DATE

We are prepared to offer you a great team that will provide you with the best technical service. Do not hesitate to contact us for any enquiry. We will be pleased to help you.



IMMEDIATE DELIVERY

The inglet dispatch centre becomes the customer's real warehouse. Quality and immediacy of delivery are always our main objectives.

Verdi Basic Vertical Saw

Technical Information	72 85 10 Basic 122 cm	72 85 15 Basic 157 cm	72 85 32 Basic 210 cm	72 85 30 Basic 244 cm	72 85 40 Basic 305 cm
Saw operation	Semi-automatic	Semi-automatic	Electronic	Electronic	Electronic
Saw advancement	Manual	Manual	Automatic	Automatic	Automatic
Speed control	No	No	Yes	Yes	Yes
Saw blade	250 x 30 mm / Z80	250 x 30 mm / Z80	250 x 30 mm / Z80	250 x 30 mm / Z80	250 x 30 mm / Z80
Max. cutting height	122 cm / 48"	157 cm / 61"	210 cm / 82,7"	244 cm / 96"	305 cm / 120"
Engine power	1,5 hp	1,5 hp	1,5 hp	1,5 hp	1,5 hp
Engine speed	2700 RPM	2700 RPM	2700 RPM	2700 RPM	2700 RPM
Voltage	220 V / 110 V	220 V / 110 V	220 V / 110 V	220 V / 110 V	220 V / 110 V
Dimensions	212 x 250 x 50 cm	242 x 250 x 50 cm	298 x 250 x 50 cm	345 x 250 x 50 cm	395 x 250 x 50 cm
Weight	125 Kg / 276 lb	145 Kg / 319 lb	162 Kg / 357 lb	178 Kg / 393 lb	205 Kg / 452 lb
Shipping dimensions A	260 x 70 x 62 cm	260 x 70 x 62 cm	410 x 70 x 62 cm	410 x 70 x 62 cm	410 x 70 x 62 cm
Shipping weight A	137 Kg	149 Kg	172 Kg	184 Kg	201 Kg
Shipping dimensions B	161 x 131 x 13 cm	195 x 131 x 13 cm	197 x 132 x 13 cm	197 x 140 x 13 cm	197 x 160,5 x 13 cm
Shipping weight B	42 Kg	52 Kg	63 Kg	68 Kg	80 Kg

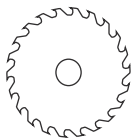

Cutting head with Saw Blade

Cut:

PVC foamboard
Aluminium composite / Dibond®
Aluminium sheets / ChromaLuxe®
Acrylics / Plexiglas®
MDF / Wood
Corrugated plastic

Cutting stoppers on each side

Mechanized aluminium base and laser engraved escale on all the base

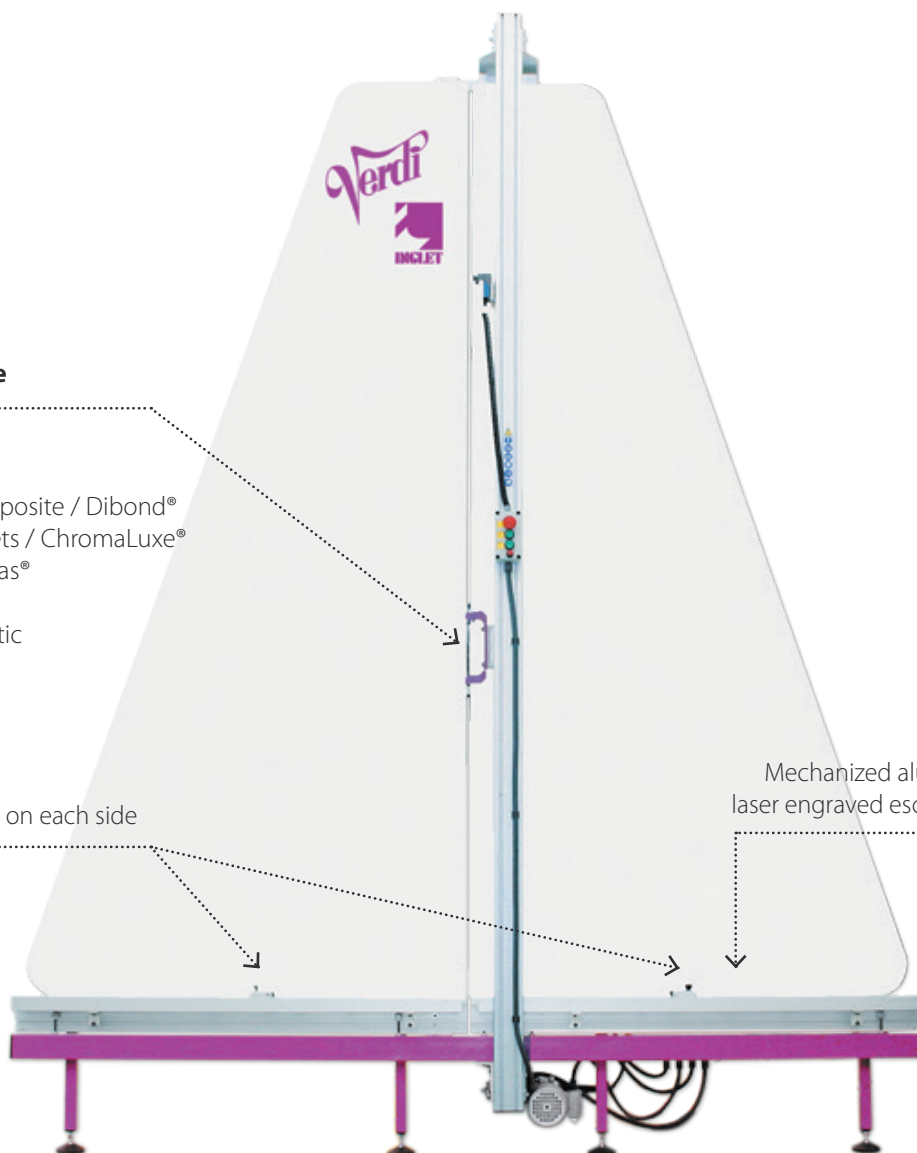

The Verdi Basic vertical saw is designed to cut any type of rigid material up to a height of 305 cm and a maximum thickness of 20 mm. The easy-to-use mechanism, combined with its powerful engine, turn the machine into an essential vertical saw for any workshop.

The Verdi Basic comes standard equipped with a universal saw. This is guided by a robust and reliable linear bearing guide system that eliminates any vibration and guarantees a straight and perfect cut all the way through.

It is available in 5 different sizes: in the 122 cm (48") and 157 cm (61.8") models the blade is manually operated. In the 210 cm (82.7"), 244 cm (96.1") and 305 cm (120.1") models the movement is automatic via a belt-driven mechanism.

Materials cut by the Verdi Basic vertical disc cutter: PVC foamboard, Aluminium composite / Dibond®, Aluminium sheets / ChromaLuxe®, Acrylics / Plexiglas®, MDF / Wood or Corrugated plastic.

A dust collector (02 12 06) is available as an accessory for dust-free use of the machine.

Safety use: acrylic cover to protect the operator from the saw blade and to hold the material during the cut.

Advancement speed regulator: regulator to adjust the cutting speed of the saw blade depending on the material that needs to be cut. (only for models 210, 244 and 305).

Adjustable limit switch: allow the possibility to adjust the stop position of the saw blade, which is useful to cut small pieces without losing time.

Reliability in use: equipped with a mechanized aluminium base to guarantee a good support for the material, which is necessary to obtain a precise and square cut.

Powerful 1.5 Hp engine: silent and powerful engine to cut very rigid materials with no limitations.

Other features: saw blade automatically returns to the upper position after each cut. Two measurement stops to accurately set up the desired measure to get. Laser system available as an accessory, useful to indicate the cutting line. All models provided with adjustable legs system.

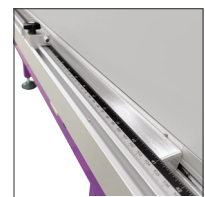

RIGIDS	Max. thickness	SEMI-RIGIDS	Max. thickness
PVC foamboard	20 mm	Corrugated plastic	20 mm
Aluminium composite / Dibond®	12 mm		
Aluminium sheets / ChromaLuxe®	3 mm		
Acrylics / Plexiglas®	12 mm		
MDF / Wood	20 mm		

ACCESSORIES	Basic 122	Basic 157	Basic 210	Basic 244	Basic 305
Pneumatic presser	14 20 20	14 20 21	14 20 22	14 20 23	14 20 24
Laser	14 20 06	14 20 06	14 20 06	14 20 06	14 20 06
1 m arm extension	14 20 02	14 20 02	14 20 02	14 20 02	14 20 02
Extra measure tab right	45 11 11	45 11 11	45 11 11	45 11 11	45 11 11
Extra measure tab left	45 11 75	45 11 75	45 11 75	45 11 75	45 11 75
Dust collector, 2 hp	02 12 06	02 12 06	02 12 06	02 12 06	02 12 06
Compressor, 1 Hp -6 l-	02 09 44	02 09 44	02 09 44	02 09 44	02 09 44
Compressor, 0.5 Hp -9 l-	02 09 38	02 09 38	02 09 38	02 09 38	02 09 38
Compressor, 1 Hp -24 l-	02 09 40	02 09 40	02 09 40	02 09 40	02 09 40
Compressor OS20P, 2 Hp -24 l-	02 09 24	02 09 24	02 09 24	02 09 24	02 09 24
Compressor L20, 2 Hp -24 l-	02 09 26	02 09 26	02 09 26	02 09 26	02 09 26
Universal saw blade	14 03 70	14 03 70	14 03 70	14 03 70	14 03 70
Saw blade for plastic	14 03 60	14 03 60	14 03 60	14 03 60	14 03 60
Saw blade for aluminium	14 03 22	14 03 22	14 03 22	14 03 22	14 03 22
Saw blade for wood	14 03 30	14 03 30	14 03 30	14 03 30	14 03 30

Verdi Twin Vertical Saw and Cutter

Technical Information	72 85 50 Twin 122	72 85 51 Twin 157	728554 Twin 210	728552 Twin 244	728553 Twin 305
Saw operation	Semi-Automatic	Semi-Automatic	Electronic	Electronic	Electronic
Blade operation	Pneumatic	Pneumatic	Pneumatic	Pneumatic	Pneumatic
Speed head control	No	No	Yes	Yes	Yes
Saw blade	250x30 mm / Z80	250x30 mm / Z80	250x30 mm / Z80	250x30 mm / Z80	250x30 mm / Z80
Max cutting height	122 cm / 48"	157 cm / 61"	210 cm / 82,7"	244 cm / 96"	305 cm / 120"
Engine power	1,5 hp	1,5 hp	1,5 hp	1,5 hp	1,5 hp
Engine speed	2700 RPM	2700 RPM	2700 RPM	2700 RPM	2700 RPM
Voltage	220 V / 110 V	220 V / 110 V	220 V / 110 V	220 V / 110 V	220 V / 110 V
Dimensions	212 x 250 x 50 cm	242 x 250 x 50 cm	298 x 250 x 50 cm	345 x 250 x 50 cm	395 x 250 x 50 cm
Weight	138 Kg / 304 lb	161 Kg / 355 lb	186 Kg / 410 lb	203 Kg / 448 lb	233 Kg / 514 lb
Shipping dimensions A	260 x 70 x 62 cm	260 x 70 x 62 cm	410 x 70 x 62 cm	410 x 70 x 62 cm	410 x 70 x 62 cm
Shipping A weight	150 Kg	165 Kg	251 Kg	209 Kg	229 Kg
Shipping dimensions B	161 x 131 x 13 cm	195 x 131 x 13 cm	197 x 132 x 13 cm	197 x 140 x 13 cm	197 x 160,5 x 13 cm
Shipping B weight	42 Kg	52 Kg	63 Kg	68 Kg	80 Kg
Shipping dimensions C	58 x 58 x 92 cm	58 x 58 x 92 cm	58 x 58 x 92 cm	58 x 58 x 92 cm	58 x 58 x 92 cm
Shipping C weight	55 Kg	55 Kg	55 Kg	55 Kg	55 Kg

Pneumatic presser

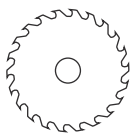

Cutting head with Saw Blade

On the left cuts:

PVC Foamboard
Aluminium composite / Dibond®
Aluminium sheets / ChromaLuxe®
Acrylics / Plexiglas®
MDF / Wood

Cutting stoppers on each side

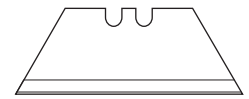

Pneumatic cutting head with blade

On the right cuts:

Foamboard
Cardboard
Honeycomb / Re-board®
Corrugated plastic
Passepartout
Glass

Mechanized aluminium base and laser engraved escale on all the base

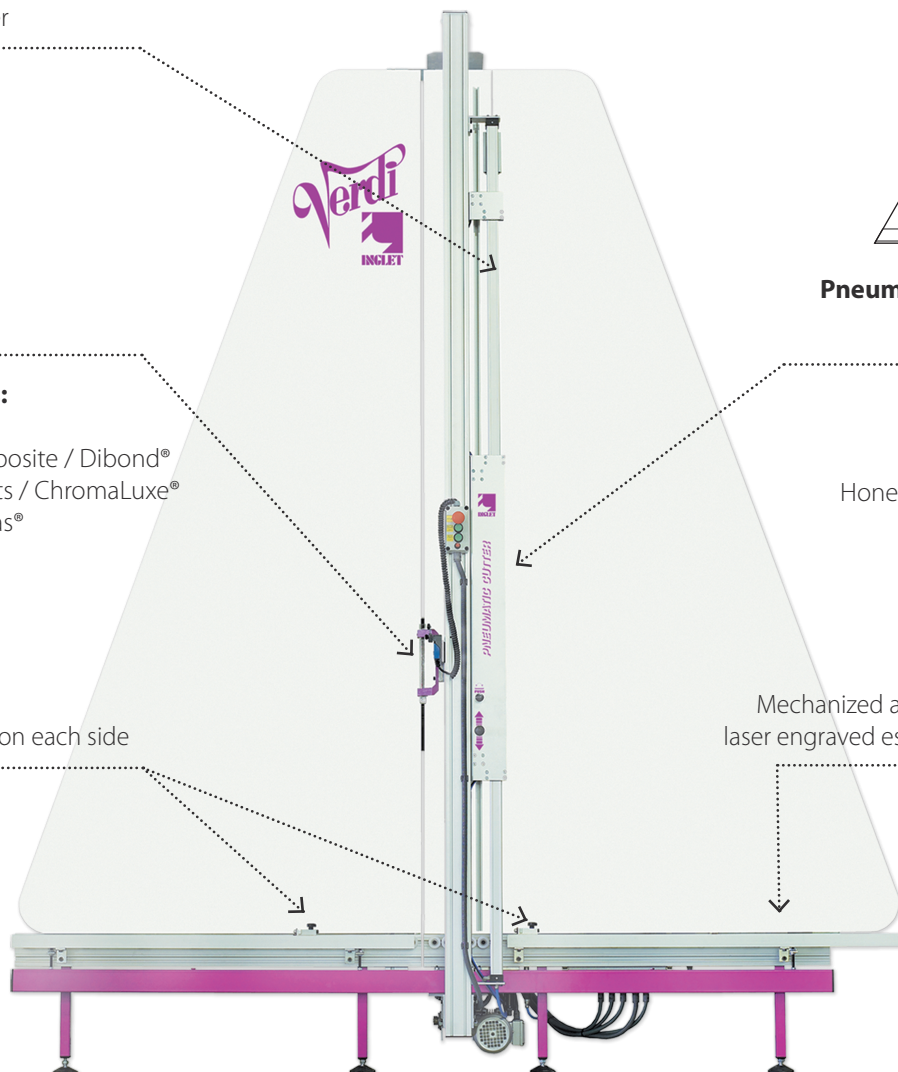

The Verdi Twin vertical cutter is designed to cut any type of rigid and semi-rigid material up to a cutting height of 305 cm and a maximum thickness of 20 mm. Its unique and complete features guarantee to cover quickly, accurately and smoothly any cutting requirement, from low volume needs to high production ones.

The Verdi Twin is equipped with two cutting systems ready to use: a saw blade on the left to cut rigid materials and a pneumatic knife on the right for semi-rigid ones. The movement of the saw blade is guided through a robust guide system that guarantees a perfect straight cut all along the way and the powerful engine guarantees an accurate result. The pneumatic movement of the knife offers an easy-to-use and fast solution to cut any semi-rigid material.

The Verdi Twin is manufactured in 5 different sizes: The saw blade is manually operated in models 122 cm (48") and 157 cm (61.8"); whereas in models 210 cm (82.7"), 244 cm (96.1") and 305 cm (120.1") the movement is automatically done through a belt-driven mechanism.

Materials cut by the Verdi Twin: PVC Foamboard, Aluminium composite / Dibond®, Aluminium sheets / ChromaLuxe®, Acrylics / Plexiglas®, MDF / Wood, Glass, Foamboard, Cardboard, Honeycomb / Reboard®, Corrugated plastic or Passepartout.

All models come equipped with a powerful 2 HP dust collector (02 12 06) to guarantee a dust-free operation.

Forward speed controller: regulator to adjust the cutting speed of the blade depending on the material to be cut. (Only for models 210, 244 and 305).

Adjustable travel stop: allows the possibility of adjusting the height where the blade should stop, very useful for cutting small pieces without wasting time.

Powerful 1.5 hp motor: silent and powerful motor to cut very rigid materials without limitations.

Easy to use pneumatic switch: pneumatic switch to quickly and easily activate the pneumatic cutter.

Pneumatic clamping system: fast system to hold the material and with the possibility of regulating the pressure if required.

Reliability in use: equipped with a mechanized aluminium base to guarantee a good support for the material, which is necessary to obtain a precise and square cut.

Other features: The blade automatically returns to the upper position after each cut. Transparent safety protector and cutting disc protector. Nylon wheels at the base for easy handling of large materials. Two measurement stops to set the desired measurement precisely. Laser available as accessory, useful to indicate the cutting line. All models equipped with adjustable legs.

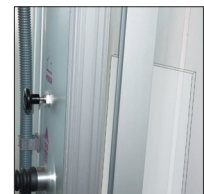

RIGIDS	Saw	Blade
PVC Foamboard	20 mm	5 mm
Aluminium composite / Dibond®	12 mm	-
Aluminium sheets / ChromaLuxe®	3 mm	-
Acrylics / Plexiglas®	12 mm	-
MDF / Wood	20 mm	-
Glass	-	6 mm * / ♦

SEMI-RIGIDS	Saw	Blade
Foamboard	-	20 mm
Cardboard	-	20 mm
Honeycomb / Re-board®		20 mm
Corrugated plastic	20 mm	5 mm
Passepartout	-	4 mm

* Optional accessory required. Only for Verdi 122 and 157 cm.

♦ Score and snap.

ACCESSORIES

Dust collector 2 hp -included-	02 12 06	Compressor, 0.5 Hp -9 l-	02 09 38	Saw blade for aluminium	14 03 22
Laser	14 20 06	Compressor, 1 Hp -24 l-	02 09 40	Saw blade for wood	14 03 30
1 m arm extension	14 20 02	Compressor OS20P, 2 Hp -24 l-	02 09 24	Blades for pneu. cutter	13 01 30
Extra measure tab right	45 11 11	Compressor L20, 2 Hp -24 l-	02 09 26	Cutting wheels for glass **	14 07 43
Extra measure tab left	45 11 75	Universal saw blade	14 03 70		
Compressor, 1 Hp -6 l-	02 09 44	Saw blade for plastic	14 03 60		

** Only for Verdi 122 and 157 cm.

Wincut Pneumatic Vertical Cutter

Información Técnica	72 85 02 Wincut 160	72 85 04 Wincut 246	72 85 03 Wincut 305
Operation	Pneumatic	Pneumatic	Pneumatic
Cutting head	Pneumatic	Pneumatic	Pneumatic
Max. cutting height	160 cm / 63"	246 cm / 96"	305 cm / 120"
Thicknesses allowed	22 mm (1,5 - 3 mm glass)	22 mm (1,5 - 3 mm glass)	22 mm (1,5 - 3 mm glass)
Dimensions	239 x 192 x 50 cm	330 x 246 x 56 cm	386 x 246 x 62 cm
Shipping dimensions A	260 x 70 x 62 cm	410 x 70 62 cm	410 x 70 x 62 cm
Weight shipping A	95 Kg	152 Kg	184 Kg
Shipping dimensions B	174 x 106 x 9 cm	174 x 144 x 10	174 x 144 x 10 cm
Weight shipping B	25 Kg	30 Kg	34 Kg

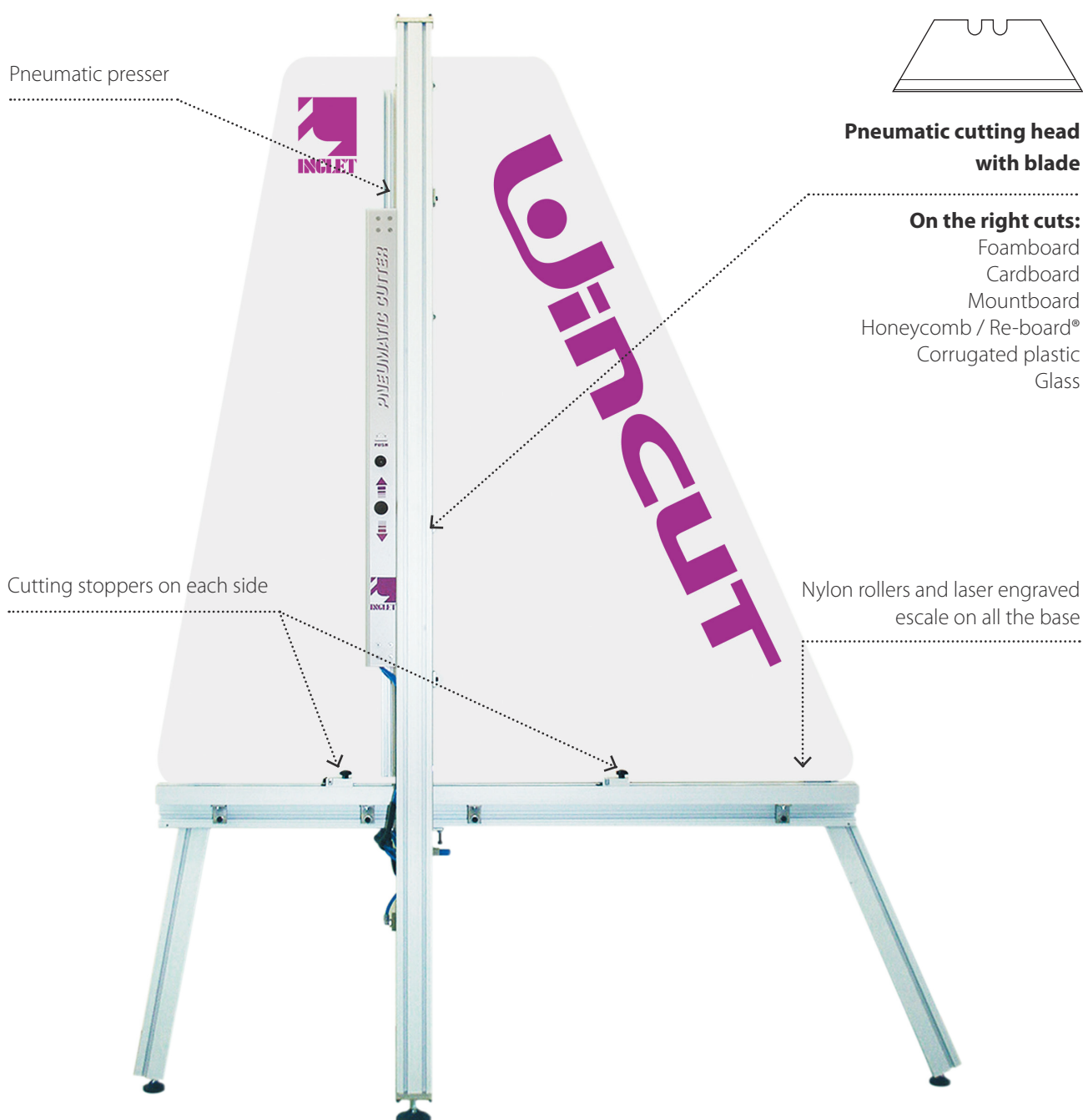

The Wincut is a pneumatic wall mounted cutter designed to cut specifically semi-rigid materials and also glass up to 305 cm. The movement of the cutting head is done through a pneumatic cylinder that guarantees a fast and smooth cut. The unit is also equipped with a pneumatic clamping system to strongly hold the material that needs to be cut.



The Wincut comes standard equipped with two interchangeable cutting heads, one to cut semi-rigid materials up to 20 mm using a special knife and a second one to cut glass up to 3 mm using a cutting wheel.

Materials cut by the Wincut: foamboard, cardboard, honeycomb / Re-board®, corrugated plastic, PVC, mountboard, glass...



The Wincut is available in three different cutting sizes: 160 cm (63"), 246 cm (96") & 305 cm (120"). Interchangeable cutting head system: Interchangeable cutting head system that allows a quick change of the cutting head.

Different cutting heads available:

Two different cutting heads available to cut semi-rigid materials and glass.



Easy to operate:

Pneumatic switch to quickly and easily activate the pneumatic knife.

Pneumatic clamping system:

Useful system to hold the material and with the possibility of regulating the pressure if it's required.

Other features:

- Equipped with nylon rollers on the base to easily move and handle large materials.
- Two measurement stops to accurately set up the desired measure to get.
- Easy to set up and square through the adjusting screw system.
- Laser system available as an accessory, useful to indicate the cutting line.

RIGIDS	Max. thickness	SEMI-RIGIDS	Max. thickness
PVC Foamboard	5 mm	Foamboard	20 mm
Glass	6 mm ◇	Cardboard	20 mm
		Honeycomb / Re-board®	13 mm
		Corrugated plastic	5 mm
		Passepartout	✓

◇ Score and snap.

ACCESSORIES

Semi-rigid materials cutting head -Included-	45 11 33
Glass cutting head -Included-	45 17 80
Laser beam for cutting head	14 20 06
Arm extension with millimeter scale -1 m-	14 20 02
Extra mesure tab -right-	45 11 11
Extra mesure tab -left-	45 11 75
Trapezoidal blade -100 u-	13 01 30
Cutting wheels for glass	14 07 43
Compressor, 1 Hp -24 l-	02 09 40
Compressor OS20P, 2 Hp -24 l-	02 09 24
Compressor L20, 2 Hp -24 l-	02 09 26

Inblade Vertical Cutter

Technical Information	728561 Inblade 165 cm	72 85 62 Inblade 210 cm	728563 Inblade 250 cm
Cutting head operation	Manual	Manual	Manual
Clam system operation	Pneumatic	Pneumatic	Pneumatic
Cutting height	165 cm / 65"	210 cm / 82"	250 cm / 98"
Dimensions A x B x C	225 x 210 x 56 cm 88,5 x 82 x 22"	268 x 210 x 56 cm 105 x 82 x 22"	310 x 210 x 56 cm 122 x 82 x 22"
Weight	70 Kg / 154 lb	84 Kg / 185 lb	102 kg / 224 lb
Packing dimensions	231 x 49 x 46 cm	278 x 49 x 46 cm	331 x 49 x 46 cm
Packing weight	94 Kg 105 Kg (with free standing)	114 Kg 126 Kg (with free standing)	130 Kg 144 Kg (with free standing)

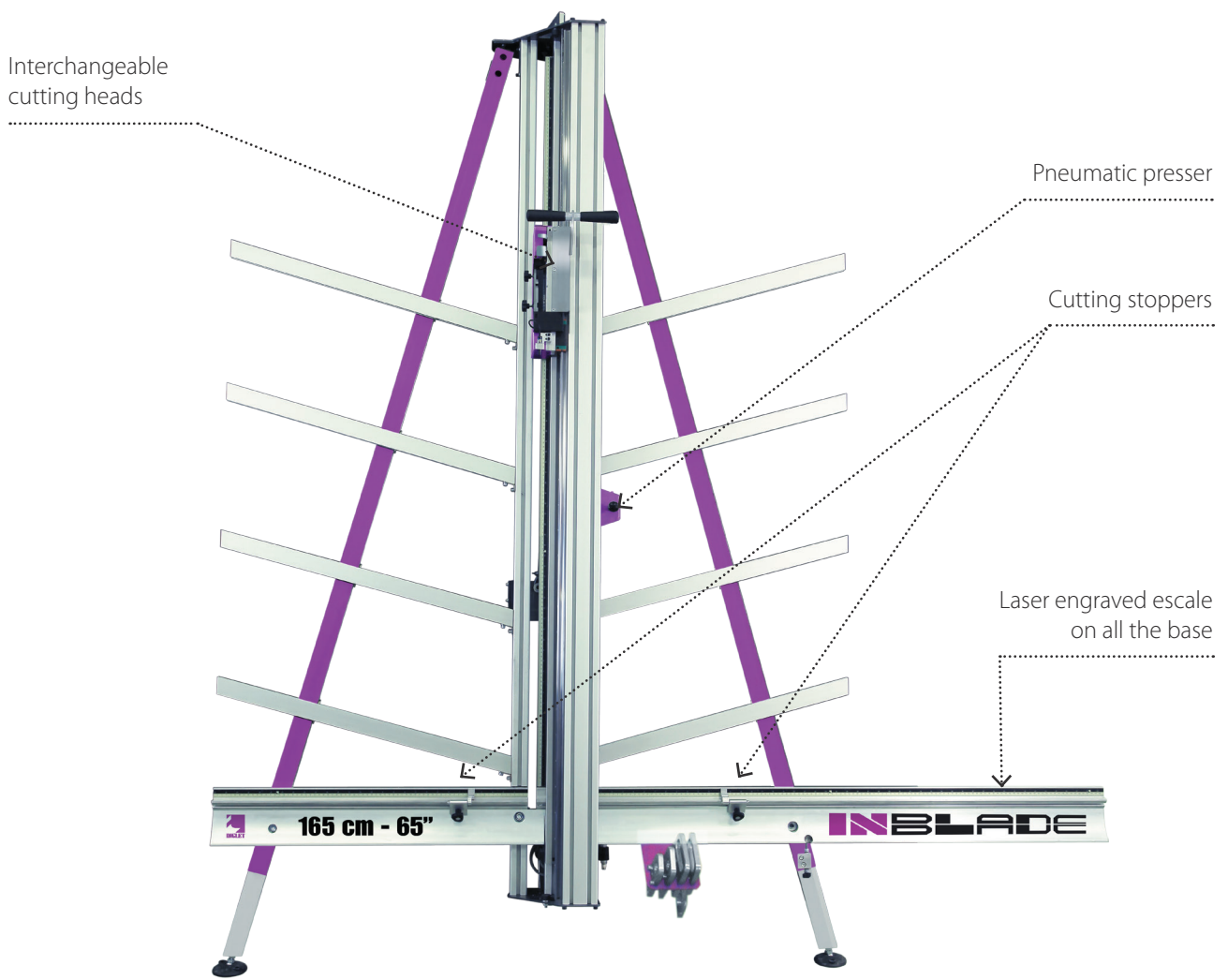





ALUMINIUM COMPOSITE
Up to 4 mm
-Included-
Ref. 45 19 90



TRIPLE BLADE
Up to 20 mm-
-Accessory-
Ref. 45 18 97



ACRYLIC
Up to 6 mm
-Accessory-
Ref. 45 18 96



SEMI-RIGIDS
Up to 13 mm
-Included-
Ref. 45 19 91



GLASS
Up to 6 mm
-Accessory-
Ref. 45 18 99



V-GROOVE RIGIDS
Up to 5 mm
-Accessory-
Ref. 45 18 98



V-GROOVE SEMI-RIGIDS
Up to 20 mm
-Accessory-
Ref. 45 19 85 / 45 19 86
+ 45 19 04

The Inblade Vertical Cutter cuts all the rigid and semi-rigid materials used in today's sign, frame and photo markets. The reliable linear bearing guide system combined with the robust structure guarantees an accurate and smooth cut of all the materials.

The interchangeable cutting head system offers an easy-to-use solution to hold all the available cutting heads and it is ready to be used by new tools developed in the future.

It is available in three cutting sizes: 165 cm (65"), 210 cm (82") & 250 cm (98") and it allows cutting the surprising maximum thickness of 20 mm.

Includes: cutting head for aluminium composites (up to 4 mm). Cutting head for semi-rigid materials (up to 13 mm).

Accurate cutting head movement: two bearing blocks located on a linear rail for a fast and accurate cutting head movement.

Pneumatic clamping: the pneumatic clamping system offers an easy, fast and reliable way to hold the material.

Other features: guided counterbalance supports the load of the cutting head to facilitate the work. Telescopic legs to find easily the most comfortable working position. Easy to set up and to square through the adjusting screw system. Can be mounted on the wall or supported by a free standing accessory.

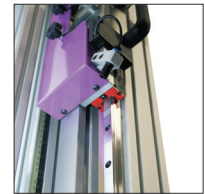
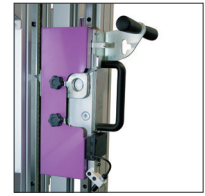

RIGIDS	Max. thickness
PVC Foamboard	13 mm
Aluminium composite / Dibond®	4 mm
Aluminium sheets / Cromaluxe®	1 mm
MDF / Wood	4 mm
Acrylics / Plexiglas®	6 mm * / ♦
Glass	6 mm * / ♦

SEMI-RIGIDS	Max. thickness
Foamboard	13 mm / 20 mm *
Cardboard	13 mm / 20 mm *
Honeycomb / Re-board®	13 mm / 20 mm *
Corrugated plastic	13 mm
Passepartout	✓

V-GROOVE	Max. thickness
Aluminium composite / Dibond®	4 mm *
Honeycomb / Re-board®	20 mm *
Foamboard	13 mm *

* Optional accessory required. ♦ Score and snap.

ACCESSORIES

Aluminium composites cutting head -Included-	45 19 90
Single blade cutting head -Included-	45 19 91
Acrylic cutting head	45 18 96
Triple blade cutting head	45 18 97
V-Groove cutting head	45 18 98
Glass cutting head	45 18 99
V-Groove cutting head support	45 19 04
Re-board® V-Groove cutting head	45 19 85
Foamboard V-Groove cutting head	45 19 86
Arm extension for Inblade -1 m-	14 20 08
Laser beam	45 06 51
Free standing Inblade, 165	45 18 01
Free standing Inblade, 210	45 18 02

Free standing Inblade, 250	45 19 13
Trapezoid blades -100 u-	13 01 30
Acrylic scoring blade -5 u-	13 01 25
V-Groove blade	13 01 71
Circular blade -2 u-	13 01 72
Re-board® V-Groove blades	13 01 79
Foamboard V-Groove blades	13 01 80
Glass cutting wheel	14 07 43
Compressor, 1 Hp -6 l-	02 09 44
Compressor, 0.5 Hp -9 l-	02 09 38
Compressor, 1 Hp -24 l-	02 09 40
Compressor OS20P, 2 Hp -24 l-	02 09 24
Compressor L20, 2 Hp -24 l-	02 09 26

Inblade Pro Vertical Cutter

Technical Information	72 85 81 Inblade Pro 165	72 85 82 Inblade Pro 210	72 85 83 Inblade Pro 250	72 85 84 Inblade Pro 305
Cutting head	Pneumatic	Pneumatic	Pneumatic	Pneumatic
Clam system	Pneumatic	Pneumatic	Pneumatic	Pneumatic
Max. cutting height	165 cm / 65 "	210 cm / 82 "	250 cm / 98 "	305 cm / 120 "
Dimensiones A x B x C	225 x 210 x 56 cm 88,5 x 82 x 22 "	268 x 210 x 56 cm 105 x 82 x 22 "	310 x 210 x 56 cm 122 x 82 x 22 "	365 x 210 x 56 cm 143 x 82 x 22 "
Weight	70 Kg / 154 lb	85 Kg / 187 lb	104 Kg / 229 lb	128 Kg / 282 lb
Packing dimensions	231 x 49 x 46 cm	278 x 49 x 46 cm	331 x 49 x 46 cm	410 x 49 x 46 cm
Packing weight	94 Kg 105 Kg (+ free standing)	115 Kg 127 Kg (+ free standing)	134 Kg 148 Kg (+ free standing)	182 Kg 198 Kg (+ free standing)

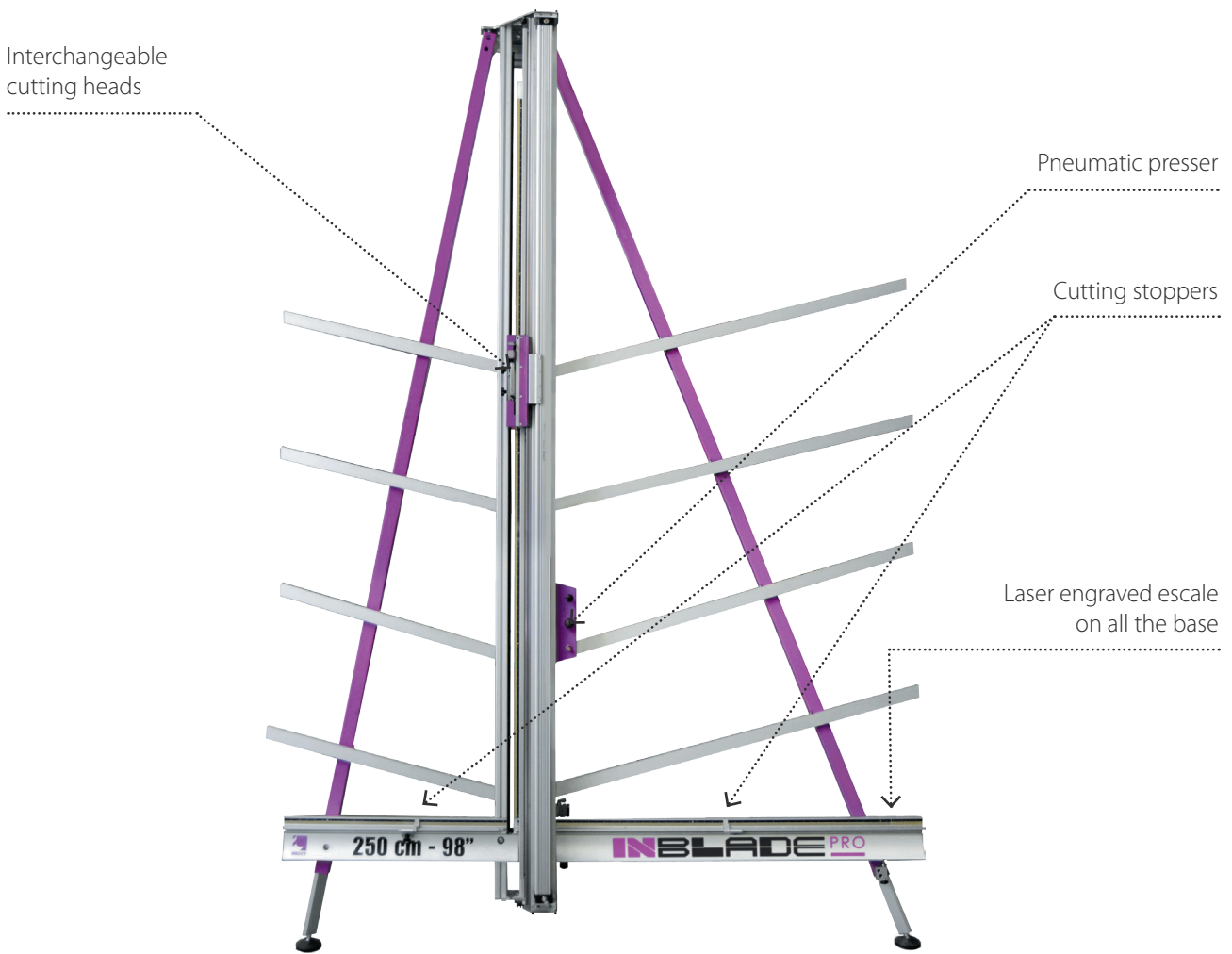

ALUMINIUM COMPOSITE
Up to 4 mm
-Included-
Ref. 45 19 90



TRIPLE BLADE
Up to 20 mm-
-Accessory-
Ref. 45 18 97



ACRYLIC
Up to 6 mm
-Accessory-
Ref. 45 18 96



SEMI-RIGIDS
Up to 13 mm
-Included-
Ref. 45 19 91



GLASS
Up to 6 mm
-Accessory-
Ref. 45 18 99



V-GROOVE RIGIDS
Up to 5 mm
-Accessory-
Ref. 45 18 98



V-GROOVE SEMI-RIGIDS
Up to 20 mm
-Accessory-
Ref. 45 19 85 / 45 19 86
+ 45 19 04

The InBlade Pro adds convenience to the already unique features of the InBlade thanks to the power of its pneumatic cylinder which, combined with a reliable linear slide guide system, moves the cutting head quickly and accurately, allowing any material to be cut without the need for manual pressure. It is also equipped with a control that regulates the speed of the cutting head according to the material to be cut, which guarantees a smooth cut for all uses. The interchangeable cutting head system offers an easy solution to work comfortably with all available cutting heads and is ready to be used by new tools developed in the future.

It is available in four cutting sizes: 165 cm (65"), 210 cm (82"), 250 cm (98") & 305 cm (120"). It allows cutting the surprising maximum thickness of 20 mm.

Included: Cutting head for aluminium composites (up to 4 mm). Cutting head for semi-rigid materials (up to 13 mm).

Robust pneumatic cylinder: To move the cutting head quickly and cut any material effortlessly.

Two bearing supports: On a linear sliding guide system for fast and precise cutting head movement.

The pneumatic clamping system: Offers an easy, fast and reliable way to hold the material. Speed control to regulate the cutting speed.

Other features: Interchangeable cutting head system. Laser to indicate the cutting line. Common for all tools. (Optional). Adjustable feet to easily find the most comfortable working position. Easy to install and square through the adjustment screw. Can be mounted on the wall or on a separate stand. • Puede ir montada en la pared o en un soporte independiente.

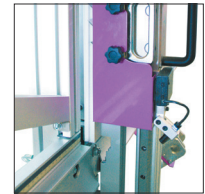
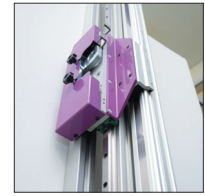

RIGIDS	Max. thickness
PVC Foamboard	13 mm
Aluminium composite / Dibond®	4 mm
Aluminium sheets / Cromaluxe®	1 mm
MDF / Wood	4 mm
Acrylics / Plexiglas®	6 mm * / ** / ◇
Glass	6 mm * / ◇

SEMI-RIGIDS	Max. thickness
Foamboard	13 mm / 20 mm *
Cardboard	13 mm / 20 mm *
Honeycomb / Re-board®	13 mm / 20 mm *
Corrugated plastic	13 mm
Passepartout	✓

ACCESSORIES

Aluminium composites cutting head -Included-	45 19 90
Single blade cutting head -Included-	45 19 91
Acrylic cutting head	45 18 96
Triple blade cutting head	45 18 97
V-Groove cutting head	45 18 98
Glass cutting head	45 18 99
V-Groove cutting head support	45 19 04
Re-board® V-Groove cutting head	45 19 85
Foamboard V-Groove cutting head	45 19 86
Arm extension for Inblade -1 m-	14 20 08
Laser beam	45 06 51
Free standing Inblade, 165	45 18 01
Free standing Inblade, 210	45 18 02

V-GROOVE	Max. thickness
Aluminium composite / Dibond®	4 mm *
Honeycomb / Re-board®	20 mm *
Foamboard	13 mm *

* Optional accessory required. ** Possible but not for daily use.
◇ Score and snap.

Free standing Inblade, 250	45 19 13
Free standing Inblade, 305	45 19 14
Trapezoid blades -100 u-	13 01 30
Acrylic scoring blade -5 u-	13 01 25
V-Groove blade	13 01 71
Circular blade -2 u-	13 01 72
Re-board® V-Groove blades	13 01 79
Foamboard V-Groove blades	13 01 80
Glass cutting wheel	14 07 43
Compressor, 1 Hp -24 l-	02 09 40
Compressor OS20P, 2 Hp -24 l-	02 09 24
Compressor L20, 2 Hp -24 l-	02 09 26

Inbest Cutter Bar

Technical Information	72 68 02 Inbest Basic 110	72 68 03 Inbest Basic 160	72 68 04 Inbest Basic 210	72 68 05 Inbest Basic 260	72 68 06 Inbest Basic 320
Cutting length	110 cm / 44"	160 cm / 63"	210 cm / 82"	260 cm / 102"	320 cm / 126"
Length (A)	138 cm / 55"	188 cm / 74"	238 cm / 93"	288 cm / 113"	348 cm / 137"
Width (B)	15,8 cm / 6,22"				
Weight	9,2 kg / 20 lb	12 kg / 26,4 lb	14,8 kg / 32,6 lb	18 kg / 40 lb	21,7 kg / 47 lb
Packing dimensions	154 x 26 x 32 cm	204 x 26 x 32 cm	254 x 26 x 32	304 x 26 x 32 cm	364 x 26 x 32 cm
Packing weight	14 Kg	18 Kg	22,50 Kg	25,50 Kg	30 Kg

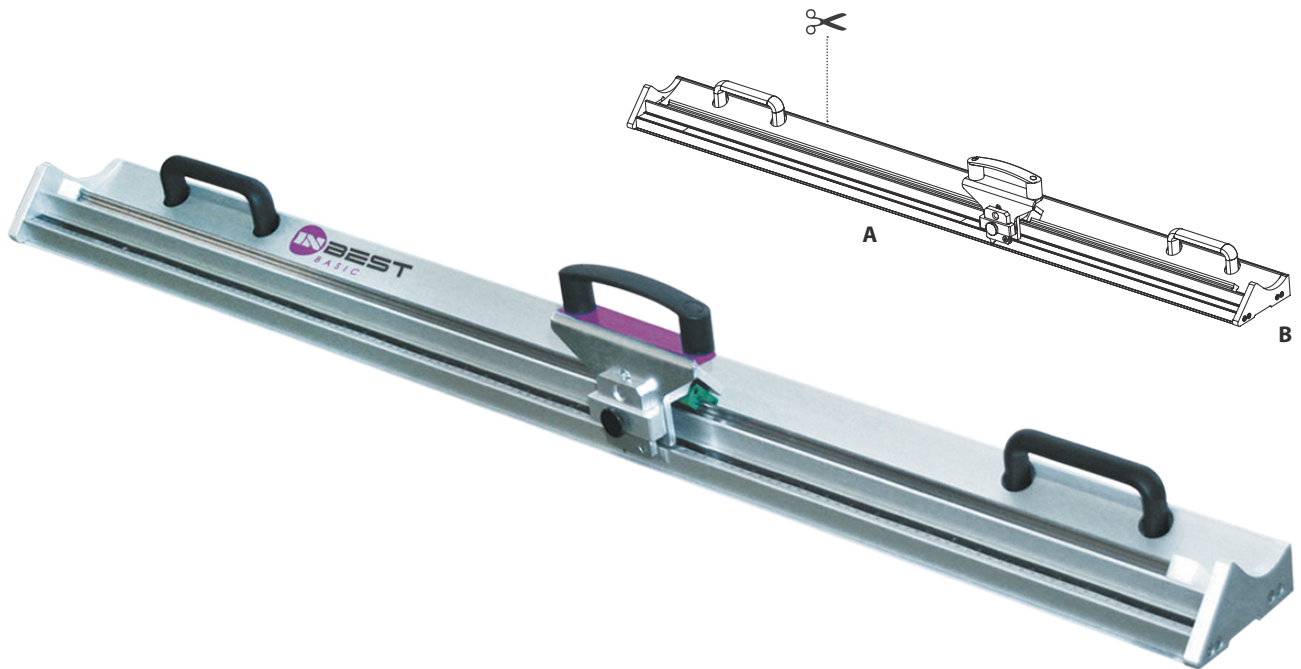

SEMI-RIGIDS Cutting Head

Up to 13 mm
(Included)

Ref. 45 22 95



CIRCULAR BLADE Cutting Head

Flexible materials
(Included)

Ref. 45 22 96



ACRYLIC Cutting Head

Up to 4 mm
(Accessory)

Ref. 45 22 92



REVERSE Cutting Head

Cut from right to left
(Accessory)

Ref. 45 22 93



EXTRA BLADE Cutting Head

Up to 20 mm
(Accessory)

Ref. 45 22 94

The new InBest range of cutter bars has been developed and constructed to satisfy all cutting requirements of a wide range of graphic materials; covering from the most delicate flexible material to any semi-rigid material.

The unique feature of using a linear bearing system to guide the cutting head guarantees an excellent performance and extreme precision, unmatched by any other cutter in the market. The InBest Basic which is the entry-level model, is equipped with a useful and easy-to-use single cutting head holder. The cut requires a soft downward hand pressure.

Includes: cutting head for semi-rigids (up to 13 mm). **Ref. 45 22 95.** Circular blade for flexible materials (up to 4 mm). **Ref. 45 22 96.**

All InBest models are available in five different sizes:
110 cm (44"), 160 cm (63"), 210 cm (82"), 260 cm (102") and 320 cm (126").

Linear bearing system: the combination of the robust bearing block with the steel linear rail, which is common to all InBest cutters, guarantees an accurate and smooth cutting head movement.

Interchangeable cutting heads: easy system to quickly interchange the cutting head to use, while the attached handle ensures an extra comfort.

Table mount elevator: available for InBest Basic and InBest Twin to offer an easy operation, raising the cutter above the material for positioning the cutting line.

Other features: User-friendly machine easy and simply to install. Plastic strip for sight line to visualize the cutting line and avoid guesswork need. Cutting thickness up to 20 mm for semi-rigid materials. Dust free operation to safely work close to printers.

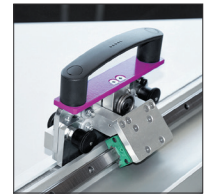

RIGIDS	Max. Thickness
PVC Foamboard	5 mm / 10 mm **
Acrylics / Plexiglas®	4 mm * / ◇
SEMI-RIGIDS	Max. Thickness
Foamboard	13 mm / 20 mm *
Cardboard	13 mm / 20 mm *
Honeycomb / Re-board®	13 mm / 20 mm *
Corrugated plastic	13 mm
Passepartout	✓

FLEXIBLES	Max. Thickness
Fabric / Textiles	✓
Plastic film	✓
Banner materials	✓
Paper	✓
Vinyl	✓
Magnetic sheets	✓

* Optional accessory required. ** The Pro model allows cutting without any problems. In the Basic and Twin models it is possible, but not for daily use. ◇ Score and snap.

ACCESSORIES

Semi-rigids cutting head (included)	45 22 95
Circular blade cutting head (included)	45 22 96
Acrylic cutting head	45 22 92
Reverse cutting head	45 22 93
Extra blade cutting head	45 22 94
Table mount elevator for InBest Basic & Twin (1 set)	45 22 01
Trapezoid blades -100 u-	13 01 30
Circular blade -1 u-	13 01 26
Acrylic scoring blade -5 u-	13 01 47

Inbest Twin Cutter Bar

Technical Information	72 68 12 Inbest Twin 110	72 68 13 Inbest Twin 160	72 68 14 Inbest Twin 210	72 68 15 Inbest Twin 260	72 68 16 Inbest Twin 320
Cutting length	110 cm / 44"	160 cm / 63"	210 cm / 82"	260 cm / 102"	320 cm / 126"
Length (A)	138 cm / 55"	188 cm / 74"	238 cm / 93"	288 cm / 113"	348 cm / 137"
Width (B)	15,8 cm / 6,22"				
Weight	9,8 kg / 21,6 lb	12,6 kg / 28 lb	15,4 kg / 34 lb	18,6 kg / 41 lb	26,5 kg / 57 lb
Packing dimensions	154 x 26 x 32 cm	204 x 26 x 32 cm	254 x 26 x 32	304 x 26 x 32 cm	364 x 26 x 32 cm
Packing weight	14,50 Kg	18,50 Kg	23 Kg	26 Kg	30,50 Kg

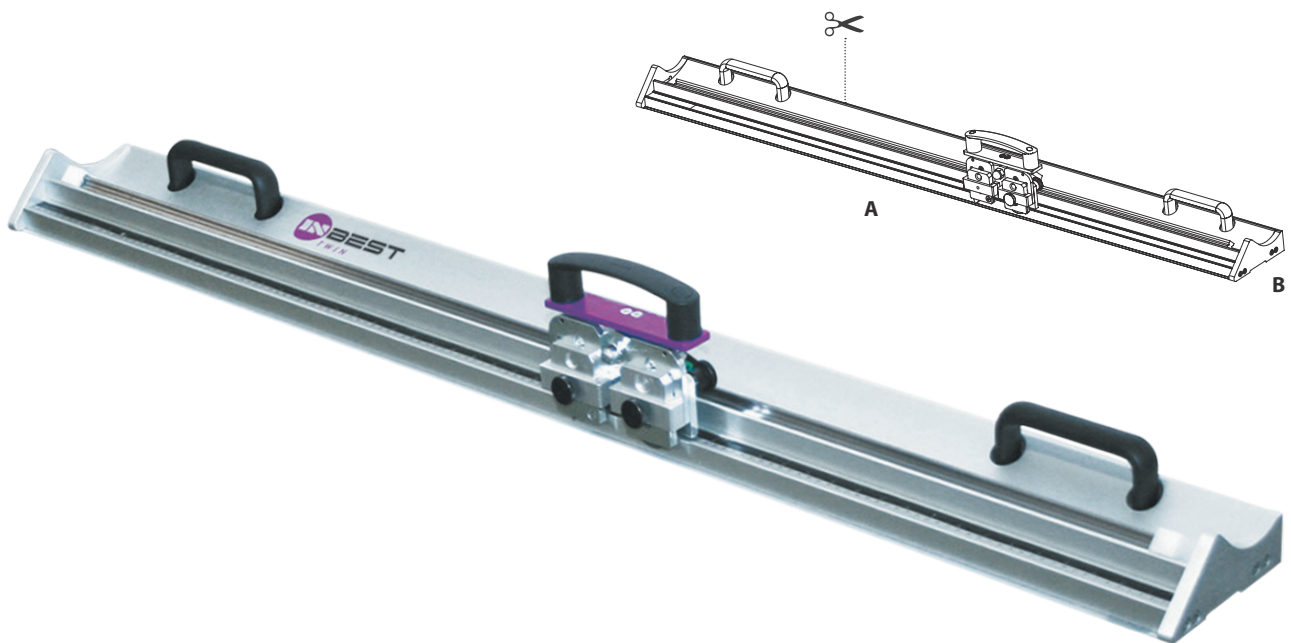

SEMI-RIGIDS Cutting Head

Up to 13 mm
(Included)

Ref. 45 22 95



CIRCULAR BLADE Cutting Head

Flexible materials
(Included)

Ref. 45 22 96



ACRYLIC Cutting Head

Up to 4 mm
(Accessory)

Ref. 45 22 92



REVERSE Cutting Head

Cut from right to left
(Accessory)

Ref. 45 22 93



EXTRA BLADE Cutting Head

Up to 20 mm
(Accessory)

Ref. 45 22 94

The new InBest range of cutter bars has been developed and constructed to satisfy all cutting requirements of a wide range of graphic materials; covering from the most delicate flexible material to any semi-rigid material.

The unique feature of using a linear bearing system to guide the cutting head guarantees an excellent performance and extreme precision, unmatched by any other cutter in the market.

The InBest Twin features a revolutionary dual cutting head system to allow the customer to have two different cutting heads installed at one time and block them if required. **The different cutting heads available** provide the equipment with a great versatility and productivity.

Includes: cutting head for semi-rigids (up to 13 mm). **Ref. 45 22 95.** Circular blade for flexible materials (up to 4 mm). **Ref. 45 22 96.**

All InBest models are available in five different sizes:

110 cm (44"), 160 cm (63"), 210 cm (82"), 260 cm (102") and 320 cm (126").

Linear bearing system: the combination of the robust bearing block with the steel linear rail, which is common to all InBest cutters, guarantees an accurate and smooth cutting head movement.

Ergonomic handle system: ergonomic handle system to comfortably cut in both directions.

Blocking the blade: possibility of blocking the blade at the cutting position to facilitate the cut of big sizes. No need of downward hand pressure.

Table mount elevator: available for InBest Basic and InBest Twin to offer an easy operation, raising the cutter above the material for positioning the cutting line.

Other features: user-friendly machine easy and simply to install. Plastic strip for sight line to visualize the cutting line and avoid guesswork need. Cutting thickness up to 20 mm for semi-rigid materials. Dust free operation to safely work close to printers.

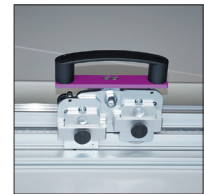
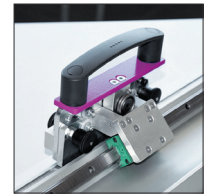

RIGIDS	Max. Thickness
PVC Foamboard	5 mm / 10 mm **
Acrylics / Plexiglas®	4 mm * / ◇
SEMI-RIGIDS	Max. Thickness
Foamboard	13 mm / 20 mm *
Cardboard	13 mm / 20 mm *
Honeycomb / Re-board®	13 mm / 20 mm *
Corrugated plastic	13 mm
Passepartout	✓

FLEXIBLES	Max. Thickness
Fabric / Textiles	✓
Plastic film	✓
Banner materials	✓
Paper	✓
Vinyl	✓
Magnetic sheets	✓

* Optional accessory required. ** The Pro model allows cutting without any problems. In the Basic and Twin models it is possible, but not for daily use. ◇ Score and snap.

ACCESSORIES

Semi-rigids cutting head (included)	45 22 95
Circular blade cutting head (included)	45 22 96
Acrylic cutting head	45 22 92
Reverse cutting head	45 22 93
Extra blade cutting head	45 22 94
Table mount elevator for InBest Basic & Twin (1 set)	45 22 01
Trapezoid blades -100 u-	13 01 30
Circular blade -1 u-	13 01 26
Acrylic scoring blade -5 u-	13 01 47

Inbest Pro Cutter Bar

Technical Information	72 68 22 Inbest Pro 110	72 68 23 Inbest Pro 160	72 68 24 Inbest Pro 210	72 68 25 Inbest Pro 260	72 68 26 Inbest Pro 320
Cutting Length	110 cm / 44"	160 cm / 63"	210 cm / 82"	260 cm / 102"	320 cm / 122"
Length (A)	146 cm / 58"	196 cm / 77"	246 cm / 96"	296 cm / 116"	356 cm / 140"
Width (B)	22,5 cm / 8,86"				
Weight	16 kg / 35 lb	20,5 Kg / 45 lb	26 kg / 57 lb	32 kg / 70.5 lb	45,7 kg / 99 lb
Packing dimensions	154 x 26 x 32 cm	204 x 26 x 32 cm	254 x 26 x 32 cm	304 x 26 x 32 cm	364 x 26 x 32 cm
Packing weight	20 Kg	26 Kg	31 Kg	38 Kg	45 kg

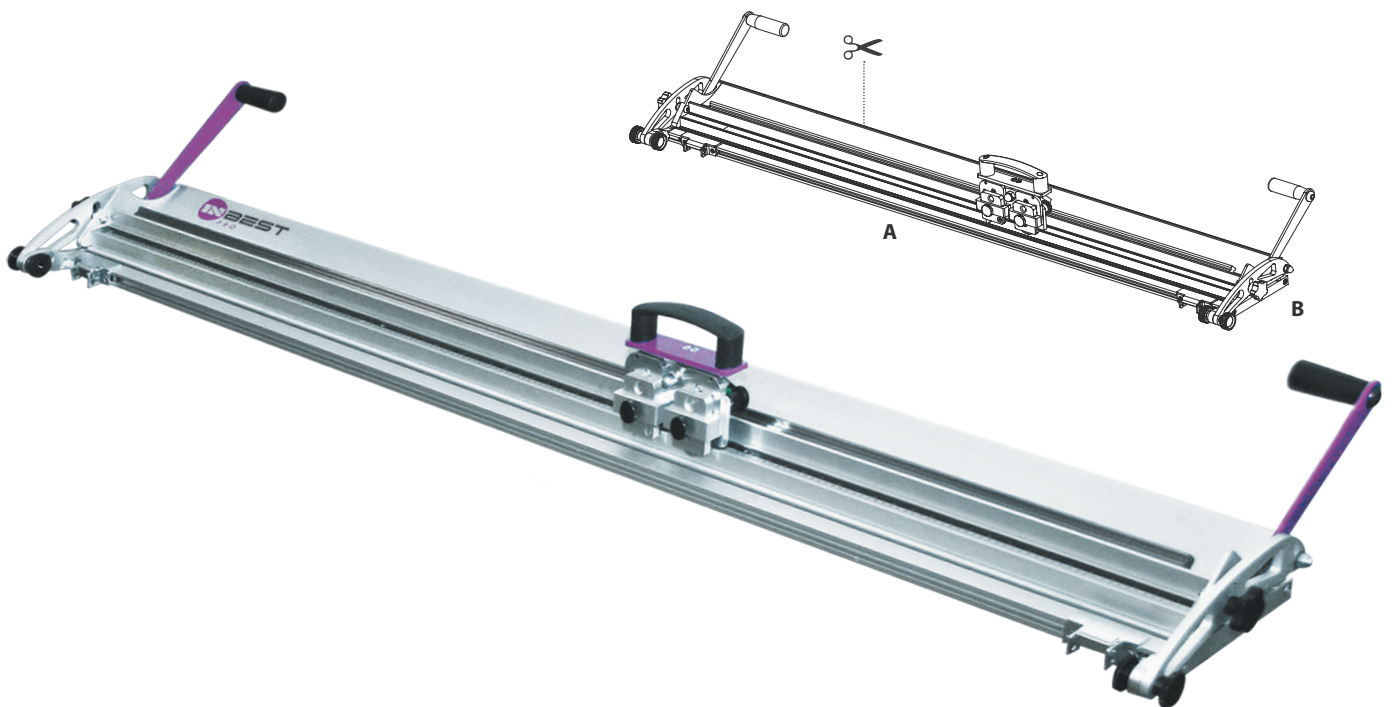

**SEMI-RIGIDS
Cutting Head**
Up to 13 mm
(Included)
Ref. 45 22 95



**CIRCULAR BLADE
Cutting Head**
Flexible materials
(Included)
Ref. 45 22 96



**ACRYLIC
Cutting Head**
Up to 4 mm
(Accessory)
Ref. 45 22 92



**REVERSE
Cutting Head**
Cut from right to left
(Accessory)
Ref. 45 22 93



**EXTRA BLADE
Cutting Head**
Up to 20 mm
(Accessory)
Ref. 45 22 94

The new InBest range of cutter bars has been developed and constructed to satisfy all cutting requirements of a wide range of graphic materials; covering from the most delicate flexible material to any semi-rigid material.

The unique feature of using a linear bearing system to guide the cutting head guarantees an excellent performance and extreme precision, unmatched by any other cutter in the market. The combination of the robust bearing block with the steel linear rail, which is common to all InBest cutters, guarantees an accurate and smooth cutting head movement.

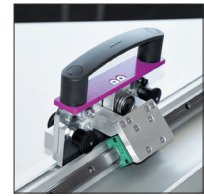

The InBest Pro adds to the equipment an integrated aluminum base with two different cutting tracks: one with a narrow groove for general purposes, to be used with the knife blade; and other with a built-in cutting strip, to be used with the circular blade.

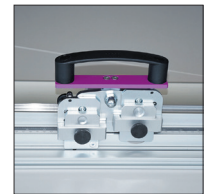

The InBest Pro is also equipped with an integral lift and hold mechanism, which can be used from both sides, to facilitate the material loading.

Includes: cutting head for semi-rigids (up to 13 mm). **Ref. 45 22 95.** Circular blade for flexible materials (up to 4 mm). **Ref. 45 22 96.**

All InBest models are available in five different sizes: 110 cm (44"), 160 cm (63"), 210 cm (82"), 260 cm (102") and 320 cm (126").

Ergonomic handle system: ergonomic handle system to comfortably cut in both directions.



Blocking the blade: possibility of blocking the blade at the cutting position to facilitate the cut of big sizes. no need of downward hand pressure.

Interchangeable cutting track: cutting position easily changeable in few seconds through the quick knob system.

Free working area: cutter bar can be placed vertically on the side of the bench to free the working area if required.



Other features: user-friendly machine easy and simply to install. Plastic strip for sight line to visualize the cutting line and avoid guesswork need. Both the cutter and the aluminum base are equipped with full length grip strips to aid clamping and protect printed media. Cutting thickness up to 20 mm for semi-rigid materials. Dust free operation to safely work close to printers.

RIGIDS	Max. Thickness
PVC Foamboard	10 mm
Acrylics / Plexiglas®	4 mm * / ♦
SEMI-RIGIDS	Max. Thickness
Foamboard	13 mm / 20 mm *
Cardboard	13 mm / 20 mm *
Honeycomb / Re-board®	13 mm / 20 mm *
Corrugated plastic	13 mm
Passepartout	✓

FLEXIBLES	Max. Thickness
Fabric / Textiles	✓
Plastic film	✓
Banner materials	✓
Paper	✓
Vinyl	✓
Magnetic sheets	✓

* Optional accessory required. ♦ Score and snap.

ACCESSORIES	
Semi-rigids cutting head (included)	45 22 95
Circular blade cutting head (included)	45 22 96
Acrylic cutting head	45 22 92
Reverse cutting head	45 22 93
Extra blade cutting head	45 22 94
Trapezoid blades -100 u-	13 01 30
Circular blade -1 u-	13 01 26
Acrylic scoring blade -5 u-	13 01 47

Table for Inbest Pro, 110 cm	14 22 02
Table for Inbest Pro, 160 cm	14 22 03
Table for Inbest Pro, 210 cm	14 22 04
Table for Inbest Pro, 260 cm	14 22 05
Table for Inbest Pro, 320 cm	14 22 06



02 09 44 NUAIR SILENT COMPRESSOR, 1 HP -6 litres-

Oil-free piston compressor, lightweight, practical and quiet, ideal for all those applications that require silence and ease of transport. Suction cup feet, which ensure optimum stability. Head unit with low speed motor, extremely silent: 66dB(A).

Technical Information

Engine	1 Hp
Litres	6
Bar	8
dB	66



02 09 38 BAMBI SILENT COMPRESSOR, 0.5 HP -9 l-

Quiet compressor with ultra-low noise and relatively small air flow. Sound levels as low as 40 dB and almost no vibration during operation. Minimal maintenance and years of trouble-free use.

- Internally coated air receptor.
- Clearview oil level control.
- Easy to use oil filling cap.
- Outlet filter 10 microns and adjustable pressure regulation.

Technical Information

L/min	50
Litres	9
Bar	8
Kw / Hp	0,34 / 0,5
dB	40
Dimensions	47 x 34 x 34 cm



02 09 40 BAMBI SILENCE COMPRESSOR, 1 HP -24 litres-

02 09 42 BAMBI SILENCE COMPRESSOR, 1 HP -50 litres-

Quiet compressor with ultra-low noise and relatively small air flow. Sound levels as low as 40 dB and almost no vibration during operation. Minimal maintenance and years of trouble-free use.

- Internally coated air receptor.
- Clearview oil level control.
- Easy to use oil filling cap.
- Outlet filter 10 microns and adjustable pressure regulation.

Technical Information

	02 09 40	02 09 42
L/min	100	100
Litres	24	50
Bar	8	8
Kw / Hp	0,68 / 1,0	0,68 / 1,0
Volts / Hz	220-240 / 50	220-240 / 50
dB	42	42
Kg	31	46
Dimensions	49 x 65 x 25 cm	55 x 88 x 29 cm

02 09 24 ABAC OS20P POLE POSITION COMPRESSOR, 2 Hp 220V -24l-

The **ABAC OS Pole Position** is designed to quietly support you in all your activities. High performance with a **silent and oil-free pump**. Easy to transport and place wherever you need it, you can always rely on its performance, with a noise level of only 59 dB(A), equivalent to a quiet conversation with a friend.

Technical Information

Litres:	24
l/min:	230
Oil:	no oil
Hp:	2
kW:	1,5
rpm:	1420
Volt:	230/50/1
Bar:	9
dB (A):	59
Dimensions:	616 x 300 x 574 mm.
Kg:	24



02 09 26 ABAC L20 POLE POSITION COMPRESSOR , 2 Hp 220V -24l-

Direct drive lubricated compressor. Excellent technology and simple operation, suitable for a wide range of applications, from nailing nails or installing staples to blowing and inflation work.

Technical Information

Litres:	24
l/min:	220
Oil:	Lubricated
Hp:	2
kW:	1,5
rpm: 2850.	2850
Volt: 230 / 50 / 1.	23 / 50 / 1
Bar: 10.	10
dB (A):	70
Dimensions:	610 x 310 x 580 mm
Kg:	25





02 12 06 INTEC DUST COLLECTOR, 2 HP

Mobile dust collector with a storage bag. **Tube and clamps not included.**

Technical Information

Main engine power	2 Hp
Number of suction nozzles	2 suction nozzles with a diameter of 100 mm
Suction flow rate	42,15 cubic m / min
Fan diameter	360 mm
Filtration bag diameter	500 mm
Storage bag diameter	500 mm
External measurements	1000 x 750 x 2000 mm
Packing dimensions	920 x 580 x 580 mm
Net weight	47 Kg
Voltage	380 V

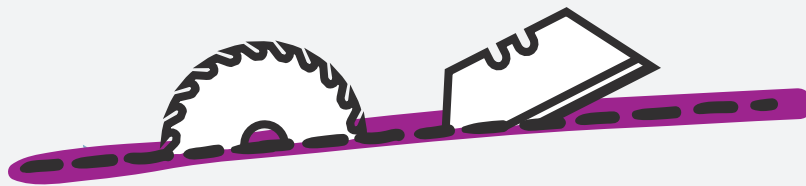

CUTTING SOLUTIONS

ARISTO[®]
Graphic Austria

ARISTO Graphic Austria GmbH

Mühlbachstraße 3 | www.aristographic.at
A - 6322 Kirchbichl | shop.aristographic.at

T: +43 5332 76229-0 | bestellungen@aristographic.at



INGLET, SLU Av. Cervera, 21 • E25300 TÀRREGA Tel. +34 973 312 312 • Fax +34 973 310 755 • Whatsapp 607 662 285
export@inglet.com • www.inglet.com • www.ingletmachinery.com • www.ingletledframes.com

08062022